

Fixing frame - EV-T2SF-EM - 1627637

Please be informed that the data shown in this PDF Document is generated from our Online Catalog. Please find the complete data in the user's documentation. Our General Terms of Use for Downloads are valid (<http://phoenixcontact.com/download>)



CHARX connect, Fixing frame, front protective cover screw connection, For attaching to infrastructure charging sockets, Type 2, IEC 62196-2, Front mounting, Generation 1 Easy Mount, Without logo

Product Description

Fixing frame for Infrastructure Socket Outlet

Your advantages

- ✓ Developed and produced in accordance with the IATF 16949 automotive standard and ISO 9001
- ✓ Individual branding, thanks to the use your own logo
- ✓ Reliable protection of your socket outlet from weather and vandalism

Key Commercial Data

Packing unit	1 pc
GTIN	 4 055626 346106
GTIN	4055626346106
Weight per Piece (excluding packing)	40.000 g
Custom tariff number	39269097
Country of origin	Germany

Technical data

Product definition

Type	front protective cover screw connection
Application	For attaching to infrastructure charging sockets
Affixed logo	Without logo
Design	Generation 1 Easy Mount
Standards/regulations	IEC 62196-2
Charging standard	Type 2
Charging mode	Mode 3, Case B

Dimensions

Fixing frame - EV-T2SF-EM - 1627637

Technical data

Dimensions

Height	77.4 mm
Width	77.2 mm
Depth	11.5 mm
Bore dimensions	60 mm x 60 mm

Ambient conditions

Ambient temperature (operation)	-30 °C ... 50 °C
Ambient temperature (storage/transport)	-40 °C ... 80 °C

Mounting

Possible mounting positions	Front mounting
	Front screw connection
Mounting hole diameter	< 7.00 mm (Elongated hole, for spacing see hole pattern)
Screws included in the scope of delivery	M5x20 cylinder head screws

Design

Design line	Generation 1 Easy Mount
Housing color	black
Customer variations	On request

Material

Material	Plastic
----------	---------

Environmental Product Compliance

China RoHS	Environmentally friendly use period: unlimited = EFUP-e
	No hazardous substances above threshold values

Drawings

Fixing frame - EV-T2SF-EM - 1627637

Dimensional drawing

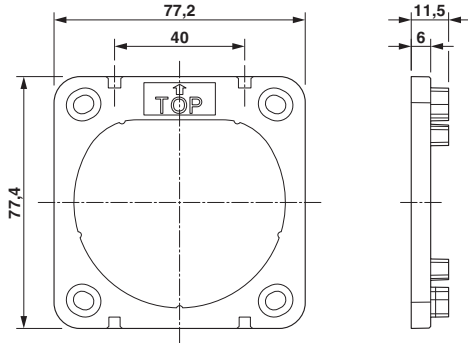

Dimensional drawing

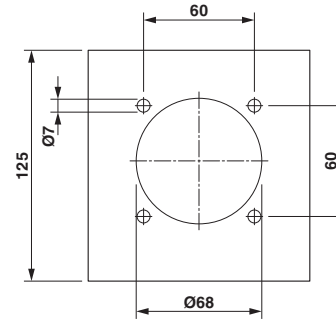

Hole image

Dimensional drawing

Schematic diagram

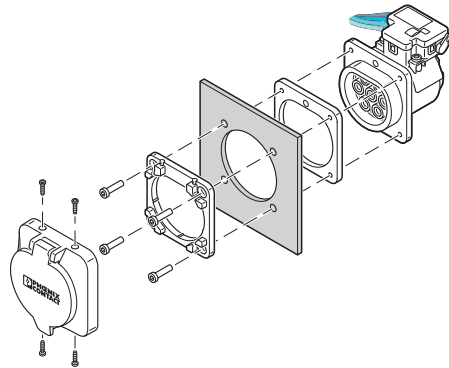

Rear mounting with front protective cover screw connection

The screw connection for a protective cover (EV-T2SC-EM) from the accessories range only supports front mounting with a corresponding fixing frame (EV-T2SF-EM). The panel thickness must not exceed 5 mm. The sealing frame that is slid on the rear must contact the housing panel flush with the flat side and must completely surround the infrastructure socket outlet.

Classifications

eCl@ss

eCl@ss 10.0.1	27144792
eCl@ss 11.0	27144792
eCl@ss 4.0	272607xx
eCl@ss 4.1	27260701
eCl@ss 5.0	27260701
eCl@ss 5.1	27059110
eCl@ss 6.0	27261200
eCl@ss 7.0	27440208

Fixing frame - EV-T2SF-EM - 1627637

Classifications

eCl@ss

eCl@ss 9.0	27144792
------------	----------

ETIM

ETIM 2.0	EC000241
ETIM 3.0	EC002061
ETIM 4.0	EC002061
ETIM 6.0	EC002884
ETIM 7.0	EC002884

UNSPSC

UNSPSC 6.01	30211923
UNSPSC 7.0901	39121522
UNSPSC 11	39121522
UNSPSC 12.01	39121522
UNSPSC 13.2	39121522
UNSPSC 18.0	39121522
UNSPSC 19.0	39121522
UNSPSC 20.0	39121522
UNSPSC 21.0	39121522

Accessories

Accessories

Infrastructure socket outlet

Socket Outlet - EV-T2M3SE12-3AC32A-0,7M6,0E14 - 1627693



CHARX connect, Socket Outlet, front protective cover screw connection, Optimized insertion and withdrawal forces, For charging electric vehicles (EV) with alternating current (AC), Compatible with infrastructure charging plugs, Type 2, IEC 62196-2, 32 A / 480 V (AC), Single wires, length: 0.7 m, Locking actuator: 12 V, 4-position, Rear panel mounting, Generation 1 Easy Mount, "PHOENIX CONTACT" logo

Socket Outlet - EV-T2M3SE12-3AC32A-0,7M6,0E12 - 1627633



CHARX connect, Socket Outlet, front protective cover screw connection, For charging electric vehicles (EV) with alternating current (AC), Compatible with infrastructure charging plugs, Type 2, IEC 62196-2, 32 A / 480 V (AC), Single wires, length: 0.7 m, Locking actuator: 12 V, 4-position, Rear panel mounting, Generation 1 Easy Mount, "PHOENIX CONTACT" logo

Fixing frame - EV-T2SF-EM - 1627637

Accessories

Protective cover for Socket Outlet

Protective covers - EV-T2SC-EM - 1627635



CHARX connect, Protective covers, self-closing, front protective cover screw connection, For attaching to infrastructure charging sockets, Type 2, IEC 62196-2, Front mounting, Generation 1 Easy Mount, Embossed PHOENIX CONTACT logo